



 **SVAGO**TM

SV-500 Use and Care Manual

V 1.0

Thank you for purchasing this Svage Zero Gravity recliner.
To ensure that you don't overlook any of your chair's features, and that you use your chair safely, read this manual carefully. Then sit back, relax, and enjoy!

TABLE OF CONTENTS

IMPORTANT SAFETY INSTRUCTIONS	1-2
CHAIR COMPONENTS	3
CHAIR INSTALLATION	4-6
CHAIR SPECIFICATIONS	7
CHAIR DIMENSIONS	8
PLACING THE CHAIR	9
PREPARATIONS PRIOR TO USE	10
OPERATION GUIDE	11-14
MAINTENANCE PROCEDURES	15
TROUBLESHOOTING	16
WARRANTY INFORMATION	17-19
Warranty Card (Attachment)	

IMPORTANT SAFETY INSTRUCTIONS

When using an electrical appliance, basic precautions should always be followed, including the following:

DANGER: To reduce the risk of electrical shock, always unplug your Svago recliner from the electrical outlet immediately after using and before cleaning.

WARNING: To reduce the risk of burns, fire, electric shock or injury to persons:

- Do not put hands or fingers near the footrest mechanism or the under side of the chair while this product is running. Touching the mechanism can result in injury.
- If the supply cord is damaged, it must be replaced by the manufacturer or its service agent or a similarly qualified person in order to avoid a hazard.
- An appliance should never be left unattended when plugged in. Unplug from outlet when not in use, and before putting on or taking off parts.
- Close supervision is necessary when this product is used by, on, or near children, invalids, or disabled persons. Keep children away from extended foot support (or other similar parts).
- Use this product only for its intended use as described in this manual. Do not use attachments not recommended by the manufacturer.
- Never operate this product if it has a damaged cord or plug, if it is not working properly, if it has been dropped or damaged, or dropped into water. Return this product to a service center for examination and repair.
- Do not carry this appliance by supply cord or use cord as a handle.
- Always keep the power cord away from heated surfaces.
- Never operate this product with the air openings blocked. Keep the air openings free of lint, hair, and the like.
- Never drop or insert any object into any opening.
- Do not use outdoors.
- Do not operate where aerosol (spray) products are being used or where oxygen is being administered.

- Do not use this product when standing on a damp floor, or when any part of the body is in contact with plumbing or any similar ground.
- Do not use this product if noise above normal sound is heard.
- Do not stand on or in appliance. Use only while seated.
- This appliance is not intended for use by persons (including children) with reduced physical, sensory or mental capabilities, or lack of experience and knowledge, unless they have been given supervision or instruction concerning use of the appliance by a person responsible for their safety.
- Children should be supervised to ensure that they do not play with the appliance.
- Please consult your doctor if you have any doubts about using this chair or if you are pregnant, undergoing medical treatment, using a medical electronic device or are receiving oxygen.
- Comfortable clothing is recommended while using this product.
- If you feel any abnormal discomfort during the operation of this product, turn off the power immediately and do not use the product. Consult your physician.
- **Do not pull on the AC cord.**
- When using this product after it has been in storage, check to see that the product is operating properly prior to use.
- Always confirm that there are no obstacles behind the product and that there is sufficient space to recline.
- **Do not attempt to repair this product yourself.**
- This product is designed for personal in-home use. Commercial use will void warranty.
- To reduce the risk of electric shock, this appliance has a polarized plug (one blade is wider than the other). This plug will fit in a polarized outlet only one way. If the plug does not fit fully in the outlet, reverse the plug. If it still does not fit, contact a qualified electrician to install the proper outlet. Do not change the plug in any way.



CHAIR COMPONENTS

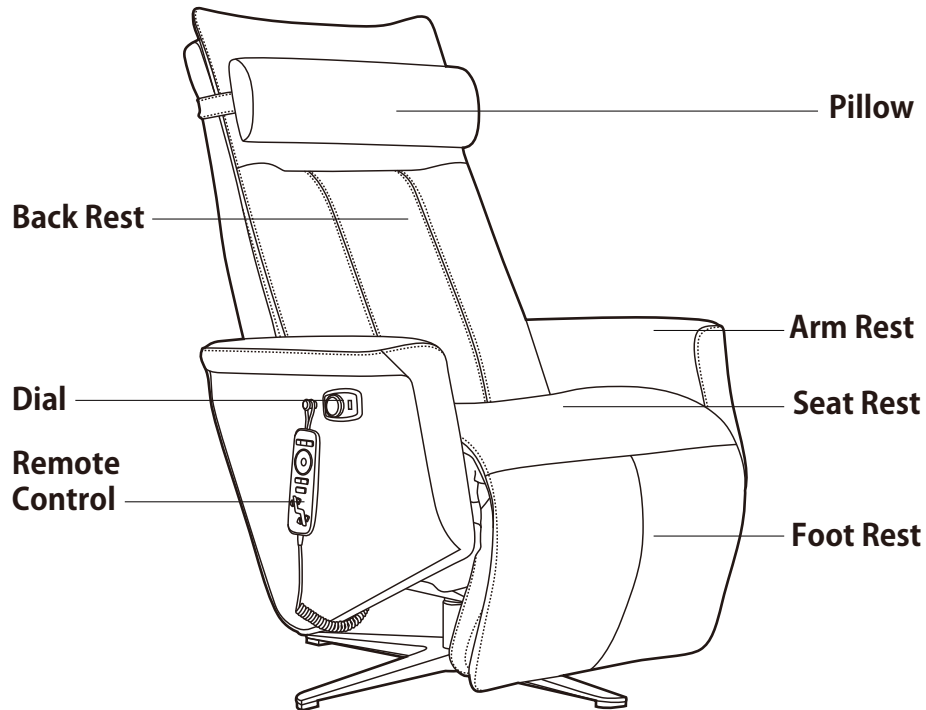

Check the accessories first

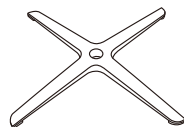
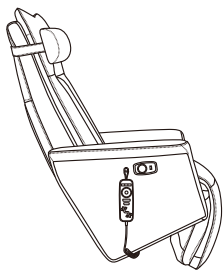

CHAIR INSTALLATION

Step 1: Open the box. Take out the chair and accessory box. Put the chair on a blanket to protect the ground.



Step 2: Remove the plastic bag from the chair. Take the accessories out.



Step 3: Align the arrows on the base and the connecting shaft, then fix the connecting shaft onto the base. Then fix the base onto the chair.

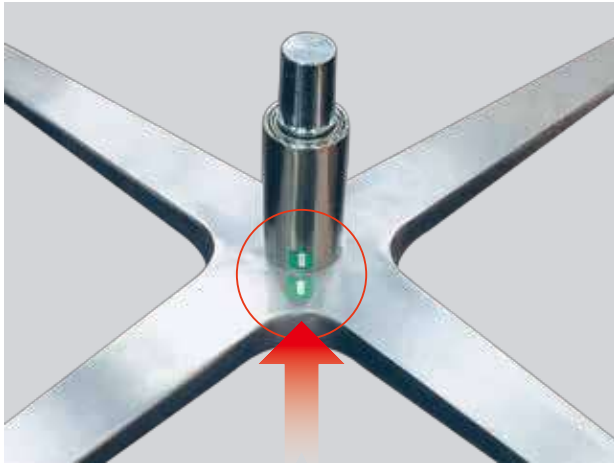

Step 4: Lift the chair up and hang the remote control on the right side board.

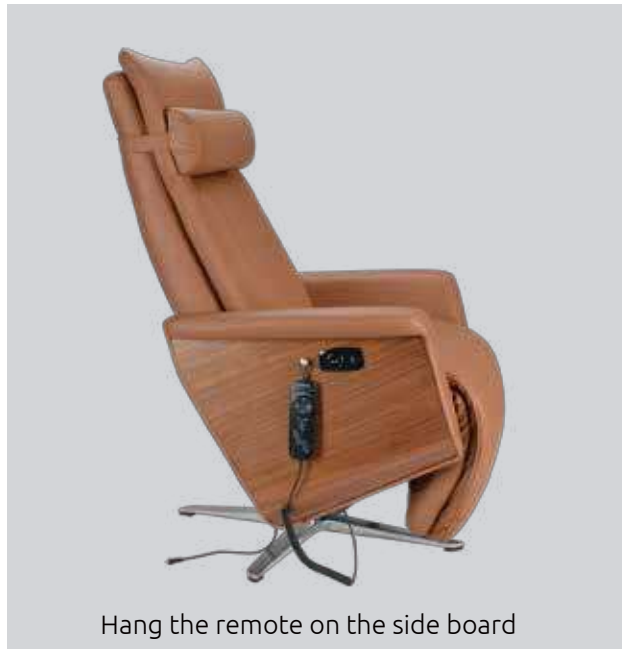

Step 5: Connect the power adaptor to the chair, then insert the power plug into the electrical socket. Now the chair is ready to go.



CHAIR SPECIFICATIONS

Specifications		Description
Model No.		SV-500
Rated Voltage		Input 110-120V
Rated Frequency		60Hz
Output		29V DC 2A
Rated Power Consumption		40W
Auto Timer		15 minutes
Dimensions (L*W*H)		Chair Upright: 35" x 32.5" x 49"
		Chair Reclined: 66" x 32.5" x 25.5"
		Packing Carton: 33"-21"x33"x52"-26"
Weight	Net Weight	131.2 lbs
	Gross Weight	151 lbs
Maximum Load Weight		330 lbs
Required Recline Clearance		25"
Usage Condition		Environmental temperature 10°C-40°C Contrasting humidity level 30-85RH
Storage Condition		Storage temperature 20°C-55°C Storage humidity level 30-85RH
Safety Features		Equipped with overheating and power surge detectors



CHAIR DIMENSIONS

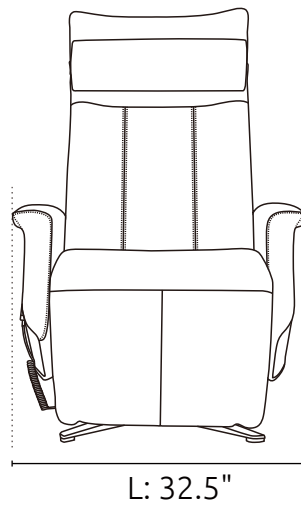
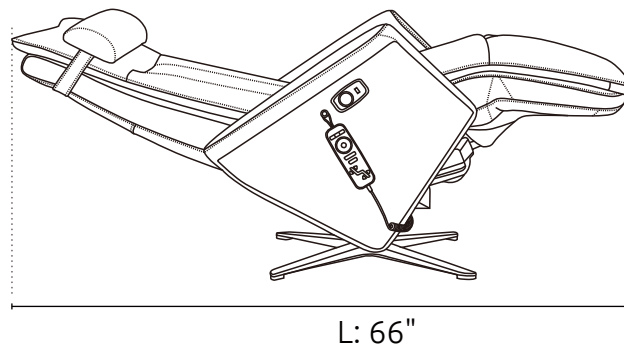
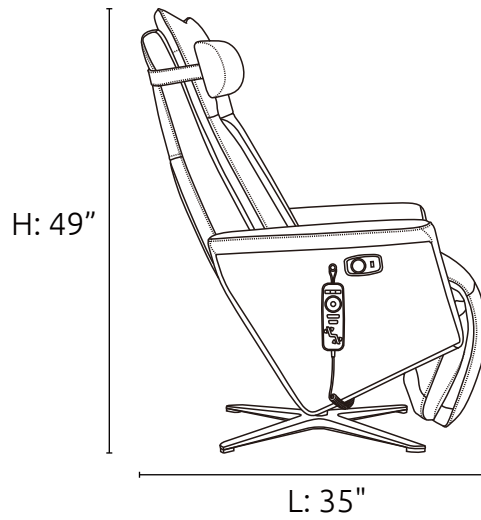

PLACING THE CHAIR

1. Lay a carpet, etc. at the set-up location. This will prevent damaging the floor, and muffles the noise during use.
2. Ensure there is sufficient space to allow the chair to recline. In order for the chair to not to touch the wall when reclined, allow a clearance of 64cm (25") to the front and back of the chair.

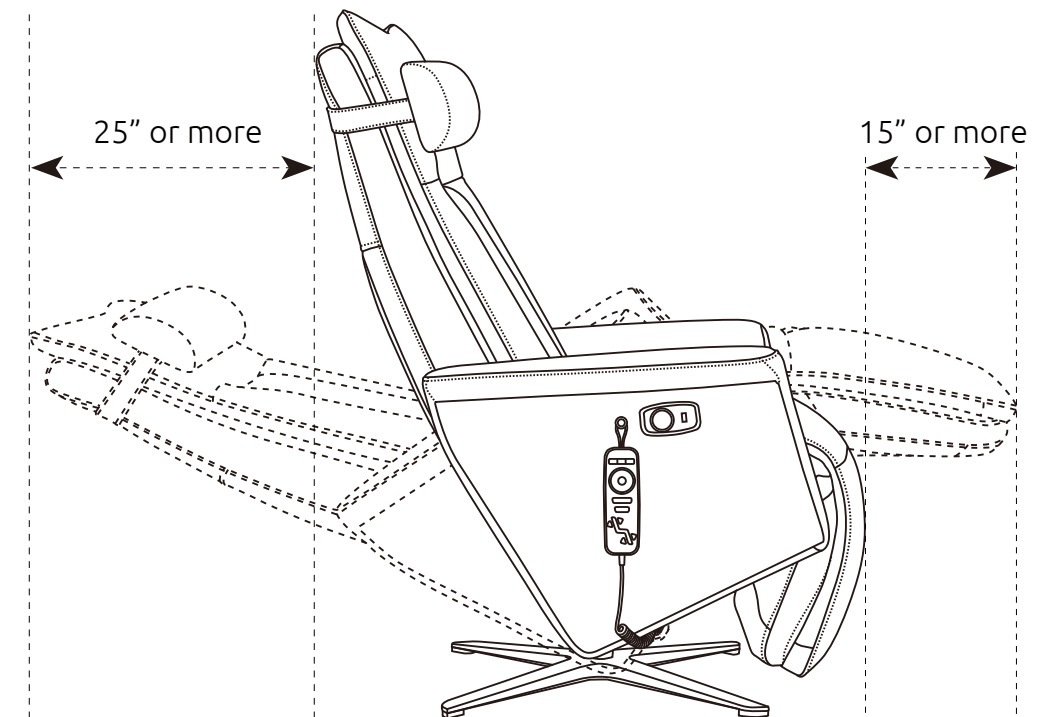

Notes

- Place the chair on a level surface.
- Keep the chair at least 1 meter (3ft) away from AV machines like a TV or radio.
- Do not keep the chair in a place where it will be exposed to direct sunshine for an extended period, or in a place near a heater where the temperature may reach high levels.

PREPARATIONS PRIOR TO USE

1. Check the power cord

Check that there is neither breakage or damage to the power adaptor.
Check that the cords are not caught or placed beneath the chair.

2. How to connect the power source

- 1) Connect the power adaptor to the chair.
- 2) Insert the power plug into an outlet.

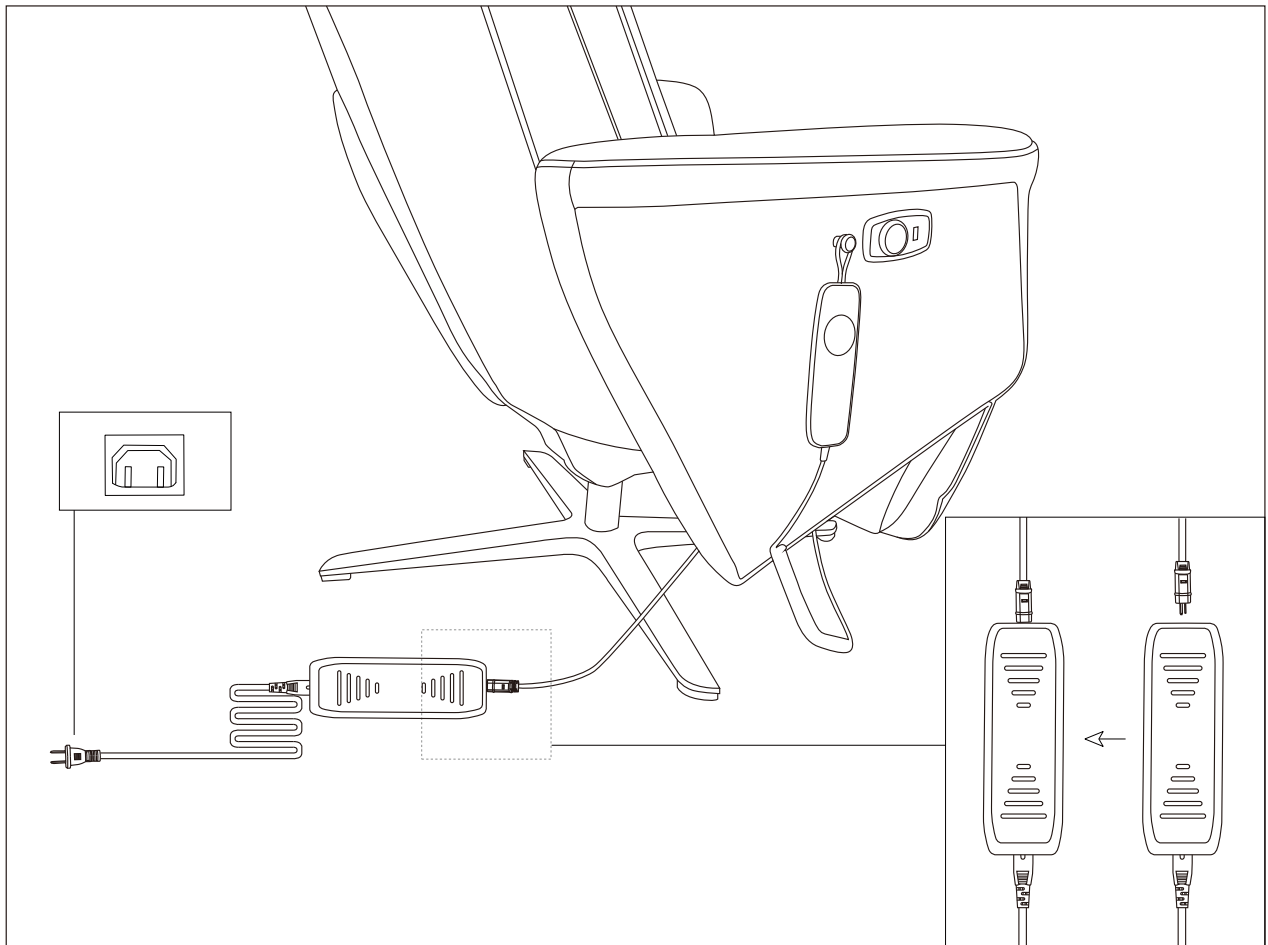

OPERATION GUIDE



Remote Control



1. Smart Wake Up Timer



Press the optional 1 to 3 hour timer button to start smart wake-up mode. When time is up, the On/Off button will flash, soft air massage will begin, and the chair will bring the user back to the home position.

2. ZGR



On pressing the ZGR button, the back rest, foot rest, and seat will be automatically adjusted to preset reclining angles. The reclining motion can be stopped by pressing either the ZGR button, the back rest recline/restore button, or the foot rest raise/restore button. After achieving the ZGR position, you may still adjust the angles of the back rest and foot rest by pressing the relevant buttons.

3. On/Off Button



On pressing the On/Off button, a light will tell you that the chair is in the idle functioning mode and will commence a massage program when you press any other function button. If during a massage function program, should you wish to suspend for any reason, please press the On/Off button and the program will cease.

4. Stretch



Press the stretch button to activate a slightly harder massage that gives special attention to your spine by slowly stretching it at different points and releasing stress.

5. Relax



Press this button to activate an air massage program. It is a wonderful all round air massage for gentle relaxation and loosening of muscles.

Note: With the air massage in action, should you wish to change the angle of the back or foot rest, the program will pause and resume automatically once the back or foot rest movement is completed.

6. Heat Heat

Press this button to commence the heating function for the lumbar region. A light will indicate that the heating function is in operation. Press the button again to cease the function. With the heating function in operation, should you wish to change the angle of the back rest or foot rest, the heating function will pause and resume automatically once the back rest or foot rest movement is completed.

7. M1 & M2

Press and hold the M1 or M2 for 2 seconds to create a new memory seating position.

8. Lumbar

Press the lumbar button to start a 15 second airbag inflation, press again to hold the current lumbar inflation position, press a third time to deflate the lumbar airbag. Lumbar support will stop working if you press the air massage button, and vice versa. Lumbar support will hold even when the chair turns off, press again or power the chair off to deflate. It takes 25 seconds for full airbag deflation.

9. Back Rest - Recline/Raise

Press and hold this button until the back rest is at your desired angle. The angle of the seat will move automatically to match with the angle of the backrest. Movement can be stopped once you let go of the button. When activating the back rest, the chair will pause all other functions.

10. Foot Rest - Restore/Raise

Press and hold this button until the foot rest is at your desired angle. Movement can be stopped once you let go of the button. When activating the back rest, the chair will pause all other functions.

Automatic Timer

The chair is programmed to operate for a period of 15 minutes, after which all functions will stop and the chair will adopt an idle mode in its current position. Note that the heating function is preset to stay on for one hour. To resume use of the chair after this period, simply press your desired function button.



Dial



MAINTENANCE PROCEDURE

WARNING

Be sure to disconnect the power plug from the outlet prior to maintenance.

NOTE

Do not attempt to use benzene. Thinner alcohol, alkaline detergent or bleaching agent for cleaning, as this may result in deformation, discoloration or cracking.

HEAD REST, BACK PAD, SEAT COVER, ARM REST, FOOT REST, PILLOW

Perform daily maintenance by wiping with a soft dry cloth. When parts are badly soiled, adopt the following maintenance procedure.

1. Soak a soft cloth in diluted neutral kitchen detergent and squeeze it well. Wipe the main unit with the damp cloth in a tapping motion.
2. Soak a cloth in clean water, and squeeze it well. Wipe off the remaining detergent with the damp cloth.
3. Wipe it with a dry cloth afterwards.
 - Do not force-dry with a dryer.
 - Do not force contact with vinyl products for an extended period. It may cause discoloration.

NOTES

- Leather is a natural material, so imperfections in the grain, dye variations, and natural markings do not constitute a defect.
- Polyurethane foam padding tends to soften and light creases may form on the leather cover over a period of three months. These are natural occurrences and do not require any type of maintenance.
- A professional cleaner should be contacted for particular types of stains such as ink marks.

TROUBLESHOOTING

WARNING

If the trouble still persists after following the proper countermeasures, stop using the chair to avoid possible accidents. Disconnect the power plug from the outlet and consult the Svago service department. Do not attempt to repair the chair, instead contact a certified technician.

Type of Troubles	Check points	Countermeasures
Operation failure	Check that the power plug is securely plugged into the outlet.	Push the power plug into the outlet securely.
	Check that the power adaptor is well connected to the chair.	Well connect the DC terminals between the chair and power adaptor.
The chair stops in the middle of operation.	This phenomenon is caused by the timer, but not a problem.	
Impossible to recline. Impossible to raise or lower the foot rest.	Check that there is no obstruction.	Remove the obstruction.

If you continue to have problems, please read the warranty card and contact the Svago service department.



WARRANTY INFORMATION

Svago products have the following warranty:

The Svago ZG Recliner provides a one-year in home and a two-year parts servicing warranty. Svago customer service will not issue Return Material Authorizations (RMAs) for products. In case of missing parts or service issues, please contact the Svago service department.

SERVICE AND TECHNICAL SUPPORT

- Consumers may contact Svago's Customer Service Department by calling us at 1-877-977-0656, between 9:00am and 5:00pm PST, Monday through Friday, or visiting our website at www.svago.com.
- Consumers are required to provide the unit serial number and dated proof of purchase (sales receipt) when they contact the Svago service department regarding a repair.
- A Svago customer service representative will attend to most consumer inquiries but in some cases a technical service specialist will be required to provide enhanced support.
- Non-warranty repair is provided on a 'per incident' basis. Svago customer service will verify that the unit has failed and provide instructions for repair. All applicable repairs, parts, shipping, handling, local tax and a 'per incident' fee will be charged for non-warranty repairs and support calls.
- Proof of purchase (original receipt) is required for all warranty repairs or servicing.

EXTENDED WARRANTIES

- Svago offers extended warranty programs to enhance ownership of Svago products. The extended warranty provides a three year limited repair or replacement warranty, with on-site service.
- Please visit www.svago.com for the latest terms and pricing for extended warranties.

PRODUCT REPAIRS

- Many Svago parts may be installed by the consumer in his/her own home with parts and instructions supplied by Svago, such as remote control replacements that do not require a technician.
- Floor model and demonstration units have a pro-rated warranty period that begins the day the model is placed on the floor and connected to an electrical outlet by the retail partner. Proof of purchase is required in order to obtain warranty service and parts. Non-warranty parts and service are available at a 'per incident' charge.
- Warranty Coverage Period: warranty coverage starts at the time the consumer purchases their chair. Proof of purchase is required for all warranty repairs. The warranty time period is measured by continuous calendar days based on the seven day week.
- Field Service: The Svago Customer Service Department will diagnose and schedule an authorized service provider to repair the chair in the customer's residence.
- Parts: all parts deemed necessary for repairs will be shipped to the customer at no charge by the Svago service department.

CONSUMER WARRANTY LIMITATIONS AND EXCLUSIONS

- Warranties are only valid in the 48 contiguous United States and Canada and are contingent upon the consumer operating the chair according to the corresponding instruction manual.
- The warranty only applies to Svago products and does not include any accessories or enhancements.



- Field service requires pre-approval and must be performed by Svago's authorized field service personnel. Field service is only available in the United States and major metropolitan areas in Canada.
- Softening of foam and filling composites in pillows, pads and memory foam occurs naturally and does not constitute a defect under this warranty.
- Fading, wear and piling of fabric occurs naturally and does not constitute a defect under this warranty.
- Natural markings, grain and dye variations in leather do not constitute a defect under this warranty.
- Warranties do not cover any loss or damage resulting from improper installation, unauthorized repairs or modifications, improper use of the electrical/power supply, loss of power, a dropped product, a malfunction or damage of an operating part due to failure to implement the manufacturer's recommended maintenance, transportation damage, theft, abuse, misuse, neglect, vandalism or environmental conditions (fire, floods, rust, corrosion, sand, dirt, windstorm, hail, earthquake or exposure to weather conditions). Loss of use during the period the product is at a repair facility or is otherwise awaiting parts or repair.
- Damage due to shipping and handling does not constitute a defect under this warranty
- Under no circumstances shall Svago or its representatives be liable for indirect consequential or incidental damage (including damages for lost profits, business interruption, bodily injury, medial problems) even if the other party has been advised of the possibility of such damages or possible problems.
- Warranties are non-transferable and shall be in lieu of any other warranty expressed or implied.
- Svago's sole liability and the purchaser's exclusive remedy shall be for repair, or at Svago's option, for the replacement of the defective part. Notwithstanding the above, if replacement parts for defective materials are not available, Svago reserves the right to make substitutions in lieu of repair or replacement.
- All warranties begin on the date of purchase, no allowance or extension is offered for delivery and/or installation.
- Warranties do not apply to rental, business, commercial, institutional or other non-residential users.



WARRANTY REGISTRATION FORM

Product Serial No. (Located on product) _____

Purchase Price: _____ Model No: _____

Date Purchased: _____

First Name: _____ Last Name: _____

Address: _____

City: _____ State: _____ Zip Code: _____

Phone: _____

Email: _____

Please mail to:
Svago Manufacturing, Inc.
861 S. Oak Park Road,
Covina, CA 91724
Tel:1-877-977-0656
Fax:1-800-521-4712
www.svago.com

Or Scan to Register Online





REDEFINING ZERO GRAVITY